

Pontos AquaCycle 2500

Making use of a finite resource –
recycle and use again.

The Pontos AquaCycle 2500:

The new generation of recycling systems

Water is a precious resource and we, at Hansgrohe, have long been committed to its protection. It is the passion for this elixir of life that has spurred us on in seeking new solutions, driven by the aspiration to find ways of using water better.

The Pontos AquaCycle is the result of this quest. The recycling system turns bath and shower water into hygienically clean process water. Fully automatically and using a purely bio-mechanical treatment method – without any chemical additives. The process water is then available for re-use, for instance for toilet flushing, cleaning buildings or irrigation.

Further developments which are worthwhile

In coming up with the **Pontos AquaCycle 2500**, we are going one step further in several respects. For instance, a special interface means the AquaCycle can be seamlessly integrated into the central building management system. Other enhanced features are the low room height it requires, only 2.10 metres, and optimized ease of servicing and maintenance. A particularly important point is: thanks to the optional combination with an advanced heat recovery system (available from the end of 2010) or with a rainwater harvesting system, the Pontos AquaCycle 2500 can reap additional energy and water savings.

Whatever technology is used: The Pontos AquaCycle 2500 supplies recycled water at constantly high, TÜV-certified quality. It's our way of giving water a second life.

Grey water recycling using the Pontos AquaCycle:

A reliable process

The filter unit with electronically controlled back-flushing of the filter.

The pre-recycling chamber for pre-treatment and main recycling chamber for the 2nd stage of the bio-mechanical treatment.

The process water chamber stores the water until re-use.

The automatic drinking water back-up on demand.

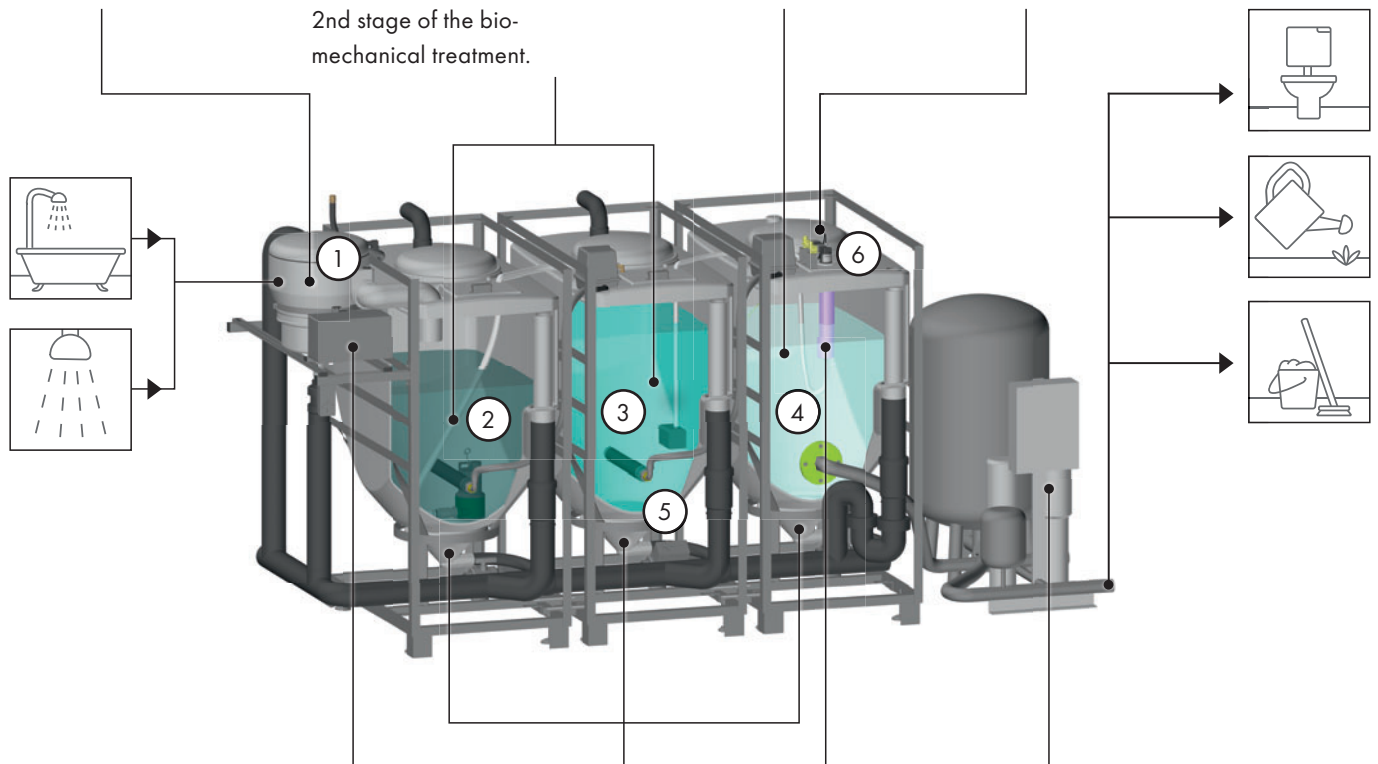

The user-friendly control unit with self-test function.

The fully automatic sediment extraction system sucks excess sediments from the biomechanical treatment process and conducts it into the drains.

The UV lamp disinfects the water, after which it is odourless and can be stored for a long period.

The pressure pump supplies the treated process water and supports the automatic back-flushing of the filter.

Short and sweet:









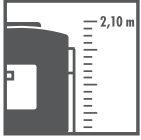

The process in a nutshell

- 1 First, a **filter** removes coarse particles (e.g. textile fluff or hairs) from the incoming grey water from the shower or bath tub.
- 2 Then the water undergoes **the first stage of biological treatment**. Here, with the supply of atmospheric oxygen, microorganisms degrade the contaminants in the water.
- 3 In the **second stage of biological treatment**, the process of the first stage is repeated.
- 4 In the final stage, the water is **disinfected** by using an **UV lamp** and stored in the process water tank until re-use.
- 5 The sediments generated during the biological treatment are automatically removed and conducted into the drains.
- 6 If insufficient process water is available, the automatic drinking water back-up ensures supply to the tapping points.

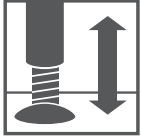

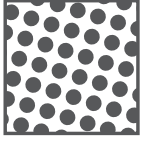
The product:

Many advantages offering clear benefits

Advantage	Benefit
 <p>Triple quality certification by TÜV (German Association for Technical Inspection): product, production and process</p>	<p>An absolutely safe and reliable system</p>
 <p>Maintenance is possible from the front</p>	<p>Ready access and greater ease of servicing and maintenance</p>
 <p>Low room height of only 2.10 metres needed</p>	<p>Small space requirement saves money; installation also possible in low rooms</p>
 <p>Tanks with "door-friendly" dimensions</p>	<p>The system fits through doors (also when it is retrofitted) with a minimum width of 800 mm</p>
 <p>The frame has adjustable feet</p>	<p>For customisation to the local conditions and perfect stability – even on uneven floors</p>
 <p>Interface to the building services management system</p>	<p>The integration of the system into the central building control system permits efficient monitoring along with other building systems</p>
 <p>Optimised filter technology</p>	<p>The water collected is used to the maximum extent without any appreciable loss</p>
 <p>Real time controlled</p>	<p>Recycling process can be programmed to a certain time</p>
 <p>Standard profiles programmed</p>	<p>Recycling profiles for different applications (hotels, sport facilities, etc.) are programmed and can easily be chosen and adapted</p>
 <p>Optional: Combination with rainwater harvesting</p>	<p>Higher saving by the substitution of drinking water by rainwater</p>
 <p>Optional: Heat recovery (available from the end of 2010)</p>	<p>The efficient use of the greywaters' thermal energy to pre-heat the service water saves energy</p>

Rainwater usage and heat recovery:

Combine the Pontos AquaCycle properly and save even more



Rainwater usage

The Pontos AquaCycle 2500 means it is now possible to combine Hansgrohe's tried-and-tested grey water recycling system with ecologically beneficial rainwater usage – and, by doing so, to achieve even greater cuts in drinking water consumption. The control unit of the system is programmed in such a way that when the water level in the process water

tank is too low, it is initially topped up with rainwater. Only when there is no longer any rainwater available the tank is automatically topped up with drinking water by an additional solenoid valve. In this way, the system exploits the full savings potential.

Heat recovery

Using heat recovery enables the thermal energy of the grey water from showers and bath tubs to be utilised to preheat service water. This saves energy and expense, reduces the CO₂ emission and helps to protect the environment.

How it works: A heat exchanger is incorporated in the first treatment stage of the Pontos AquaCycle and extracts the greywaters' thermal energy. A second heat exchanger transfers the extracted thermal energy to the service water and preheats it in this manner.

Stratified storage tank



Pontos AquaCycle



Heat exchanger in the first stage of the Pontos AquaCycle

Examples of Pontos AquaCycle application



Hall of residence for approx. 65 persons

The grey water from showers is recycled for toilet flushing use



Hotel for approx. 40 persons

The grey water from showers is recycled for toilet flushing use and irrigation



Multi-family houses for approx. 45 persons

The grey water from showers is recycled for toilet flushing use

References: Combination of grey water recycling with heat recovery



Hall of residence for 65 persons, Germany New build, Freiburg

System used: Pontos AquaCycle 3000-6
The grey water from 30 showers is recycled for 30 toilets

In addition: Integrated heat recovery unit for preheating the shower water. Saving: approx. 20% of the total energy costs for producing hot water.



Hotel for 150 guests on average, Czech Republic New build, Prague

System used: Pontos AquaCycle 4500
The grey water recycled from showers is used for toilets

In addition: Integrated heat recovery unit for preheating the shower water
Saving: approx. 80 kWh per day

Advertise your green credentials!

If your project is for a hotel, for example, then inform your clientele in their guest rooms about the innovative grey water recycling technology your hotel uses.

Our signs and our letter for your guest room folders are ideal for the purpose. We will be pleased to offer you other, customised information tools – please contact us!



Pontos AquaCycle 2500:

Technical data

Pontos AquaCycle 2500	
Empty weight of system	600 kg
System in operation	3 000 kg
Connections	
Drinking water connection	3/4" male thread
Process water connection	2" female thread
Feed into the system	DN 100 – to be vented separately via roof*
Overflow to drains	DN 100 – protect with odour trap to the drains!
The installation site must be adequately ventilated and have a floor drain	
Capacity	
Useful capacity stage 1	800 l
Useful capacity stage 2	800 l
Useful capacity stage 3	800 l
Recycling capacity	Max. 2 000 l process water per day
Max. flow rate, process water	Dependent on on-site pressure booster (PB)
Max. operating pressure, process water	Dependent on on-site pressure booster (PB)
Start-up pressure	Dependent on on-site pressure booster (PB)
Power connection	
230 V 50 Hz TN-S (L, N, PE), safety plug	
Max. current input	3.0 A
Fuse protection (on-site pre-fusing)	16 A
Power consumption	approx. 2.5 kWh/day (without on-site PB)
Rating	
Pressure booster (PB)	See PB documentation
Sediment extraction	4 W each, 12 W in all
Solenoid valve, filter back-flushing	8.5 W
Solenoid valve, drinking water top-up	8.5 W
Submersible pumps P1	78 W
Submersible pumps P2	35 W
UV disinfection:	36 W
Aeration (air blower LA 45)	47 W each, 94 W in all
Max. rated power	0.3 kW
Ambient conditions	
Ambient temperature	4° C up to 35° C
Relative humidity	max. 95 %

* In case of feed using a pumping system, it has to be throttled to 35 l/min maximum. Separate venting of the Pontos AquaCycle is necessary. An emergency overflow of the pumping system has to be provided. Subject to technical modifications and errors.



Pontos AquaCycle 2500

- Comprising 3 tanks à 800 l
- Max. treatment potential: 2 000 l/day*
- System dimensions (h x w x d): 1 820 mm x 3 073 mm x 1 343 mm
- Space requirement (h x w x d): 2 100 mm x 4 073 mm x 2 343 mm

* Depending on factors including application, consumer behaviour, number of persons, structural conditions.

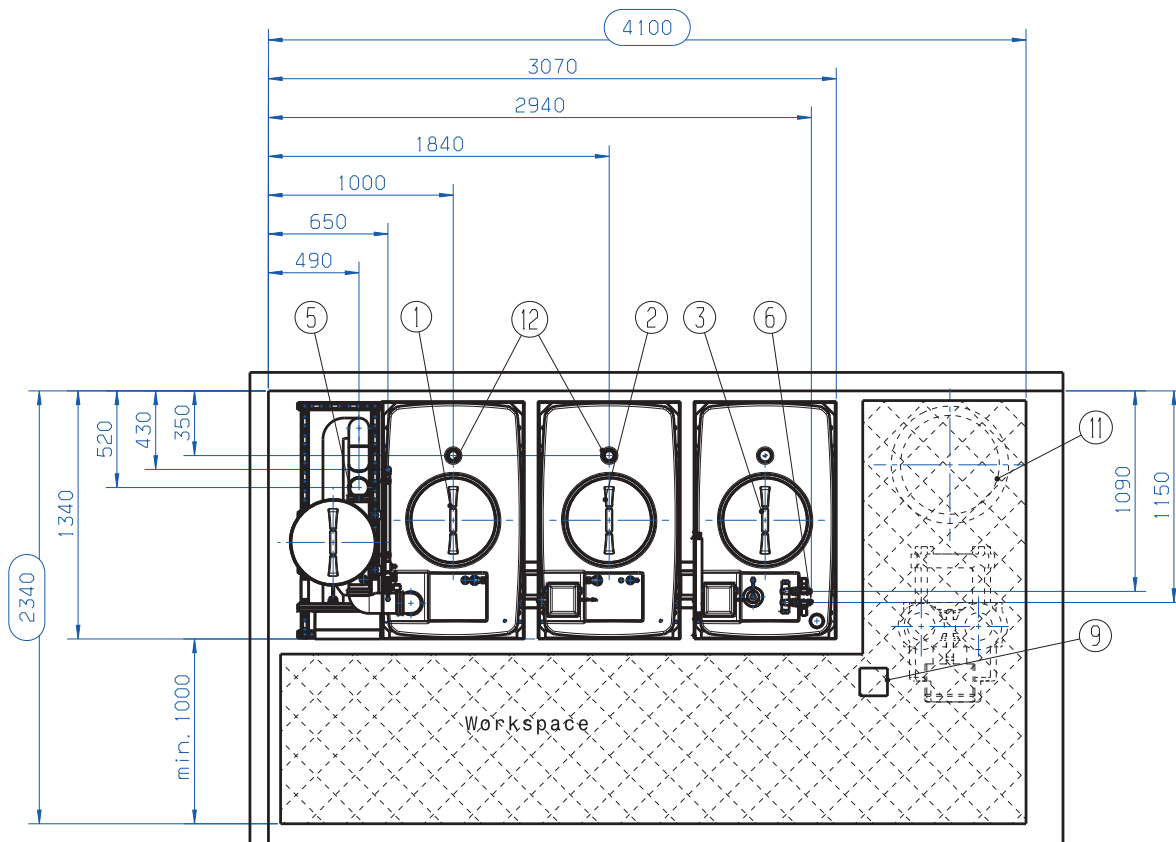
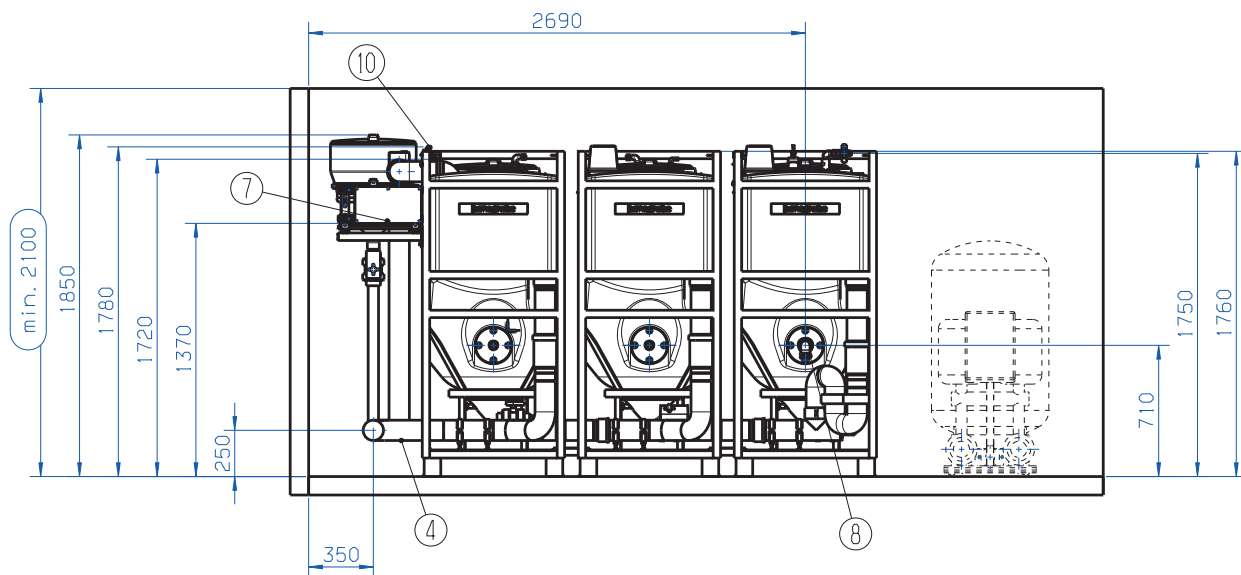

 = Required space

- | | |
|--|--|
| <ul style="list-style-type: none"> ① Pre-recycling ② Main recycling ③ Process water storage tank ④ Waste water line DN 100, transfer height 250 mm; is to be fitted with stench trap/U-bend by customer ⑤ Pre-filtration, grey water inlet DN 100 (to be ventilated separately by customer) ⑥ Drinking water back-up, transfer height 1 750 mm; max. necessary service water volume flow is to be provided by the customer; max. 4 bar; 1 x 3/4" (male thread) ⑦ Control cabinet, cable connection (from below) transfer height 1 370 mm; cable length 2 000 mm (is to be protected with a circuit breaker provided by customer) AC230V/50Hz/16A TN - S (L1 NPE) | <ul style="list-style-type: none"> ⑧ Process water connection for customer's booster pump with expansion vessel Ø 50 mm ⑨ Floor drainage (to be provided by customer) ⑩ Process water connection for filter backwashing 1 x 1/2" male thread; max. 3 bar; transfer height 1 780 mm ⑪ Expansion vessel (to be provided by customer) ⑫ Ventilation DN 70 |
|--|--|

